

# **Pilot Groundwater Monitoring Program in Northern Arizona for the Flagstaff Arboretum**



*The Arboretum Team*

Sulaiman Alsaqlawi (Civil), Krystal Serfine (Environmental),  
Da Xu (Electrical), Hong Zhang (Electrical)

CENE 476- Capstone Preparation

# Purpose

- Climate change in Northern Arizona
- Pilot Monitoring well in shallow aquifers
- Help better understand the impacts of climate change



The Arboretum at Flagstaff [1]

# Climate Impact on Northern Arizona

Southwest Experimental Garden Array (SEGA)

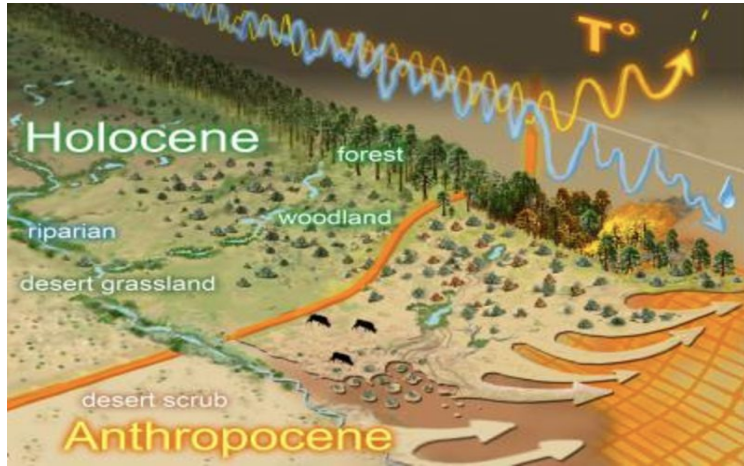

Gardens of SEGA [2]

What can our project do for  
SEGA and Arboretum?

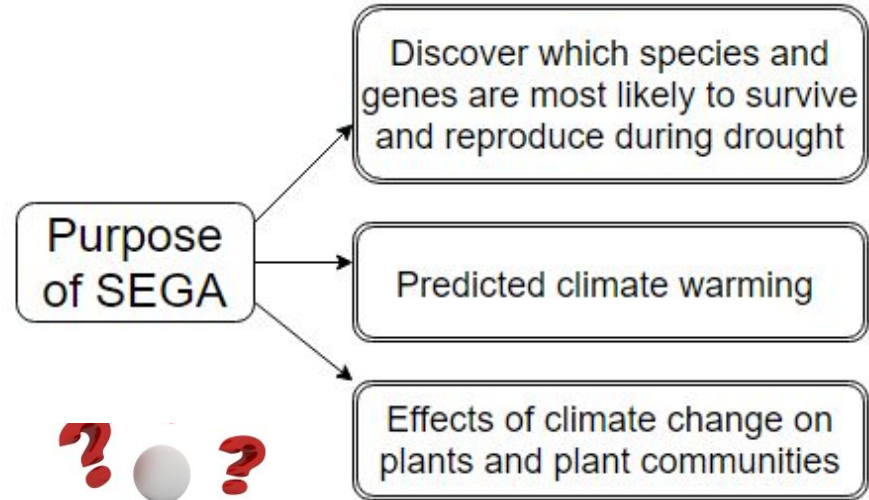

# Stakeholders



NAU SICCS working in conjunction with SEGA [4]



K-12 students [3]



Client: Flagstaff Arboretum [5]

# Technical Components

Monitoring Well and  
Sampling  
Following BEMP  
Protocol (Site Design  
and Water Extraction):

Water Quality Field  
Measurements  
YSI 9500, Del Agua,  
and Probes



Static Water Level:  
Pressure Transducer and  
Beeper Tape

Data Transmission:  
Transmission node

# Monitoring Well



Bosque Ecosystem Monitoring Program

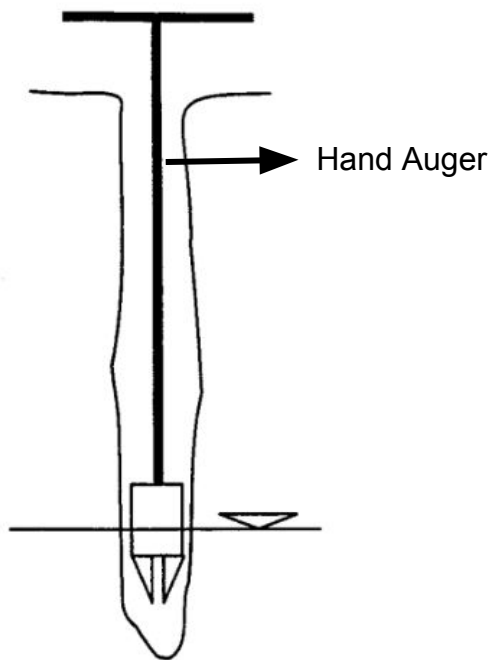

Hand Auger [6]

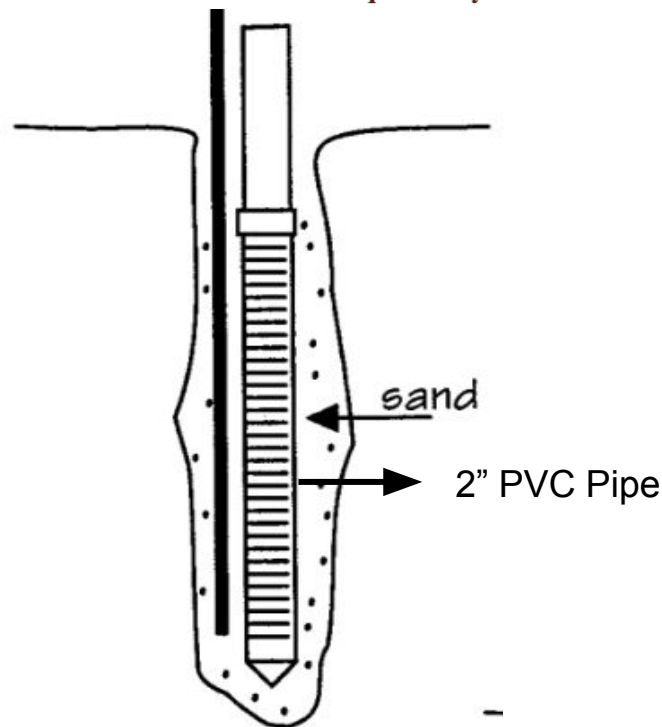

Monitoring well installation [6]

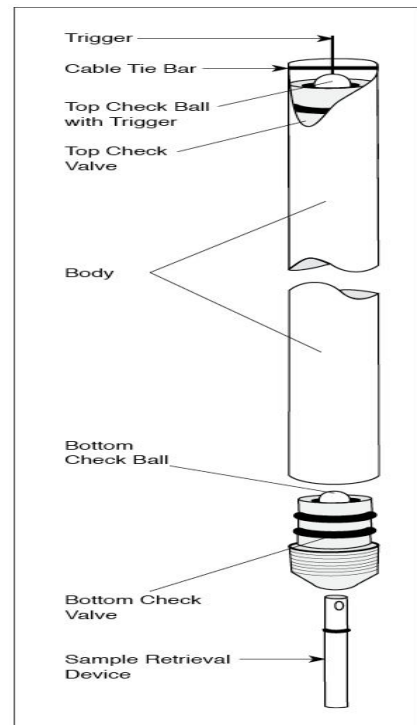

Bailer Components [7]

# Field Sampling

Upcoming site investigations on each study site will help determine what to test the water samples for

*Del Agua Testing Kit may be used for bacterial testing*



Del Agua Testing Kit [9]

*Helps test for constituents like hardness, sulfates, DO and pH.*



YSI 9500 Photometer [8]

# Use different equipments to detect the static water level change

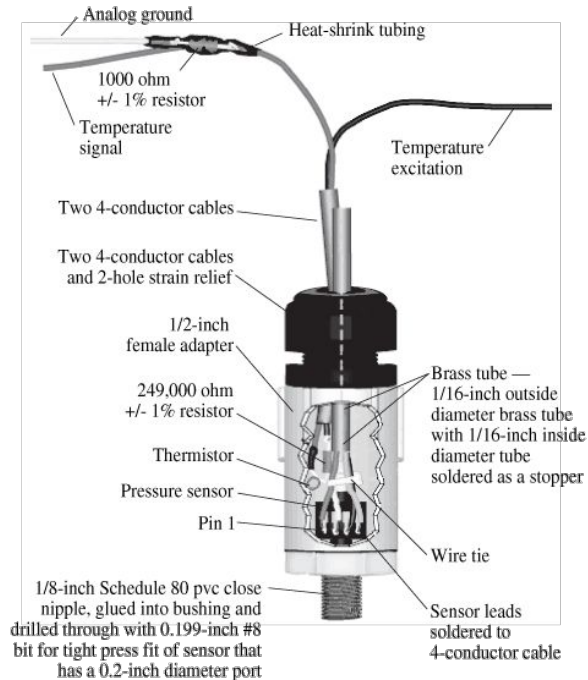

Pressure Transducer [10]

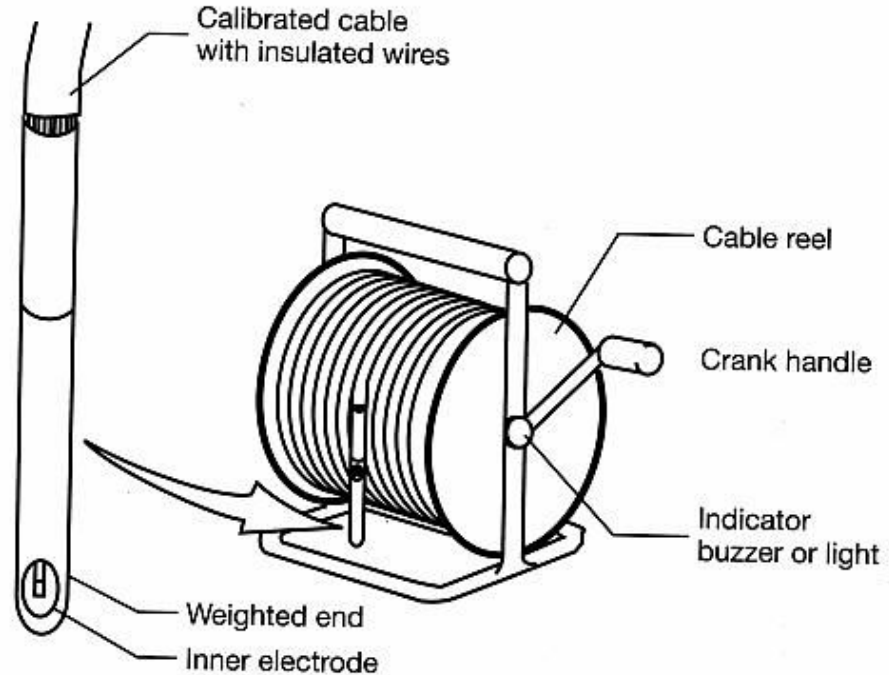

Beeper tape [11]



# Data Transmission

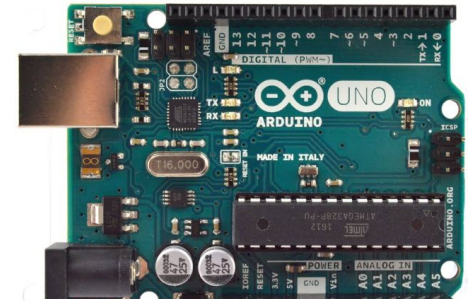
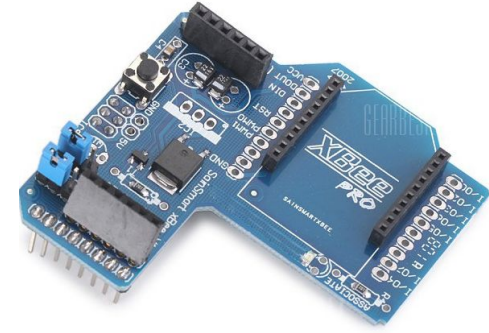
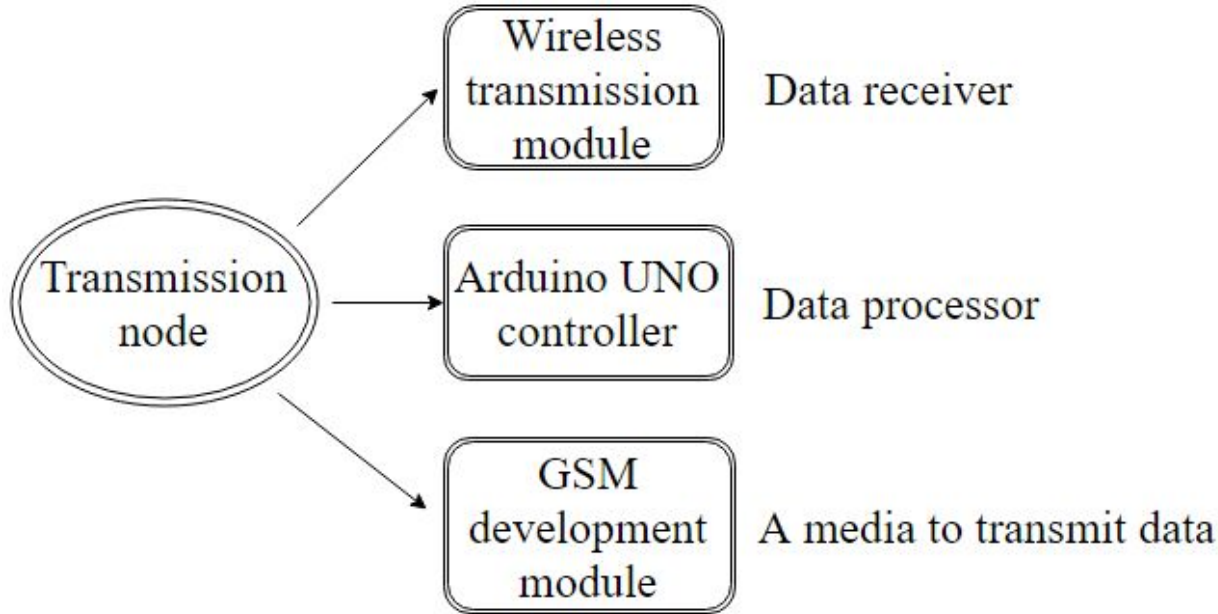

# Scope

Task	Sub-Task	Sub-Sub-Task
<b>2.1 Task 1: Site Investigation</b>	2.1.1 Preparation	2.1.1.2 Investigation
<b>2.2 Task 2: Design</b>	2.2.1 Monitoring Well	2.2.1.1 Design Monitoring Well
		2.2.1.2 Sampling Equipment
	2.2.2 Water Pressure Transducer	2.2.2.1 Sensors
		2.2.2.2 Electric Circuit
		2.2.2.3 Structure
	2.2.3 Data Collection	
	2.2.4 Data Transmission	2.2.4.1 Transmission Node
		2.2.4.2 UNO Controller
2.2.4.3 Wireless Transmission Module		
2.2.4.4 GSM/GPRS Development Version		
<b>2.3 Task 3: Building</b>	2.3.1 Building Sampling Well	
	2.3.2 Building Pressure Transducer	
<b>2.4 Task 4: Test</b>	2.4.1 Measurement Test of the Water Depth	2.4.1.1 Pressure Transducer Test
		2.4.1.2 Monitoring Well Test
<b>2.5 Task 5: Project Management</b>	2.5.1 PDT Meetings	
	2.5.2 Technical Coordination Meetings	

Table 1: Scope of Services

# Schedule

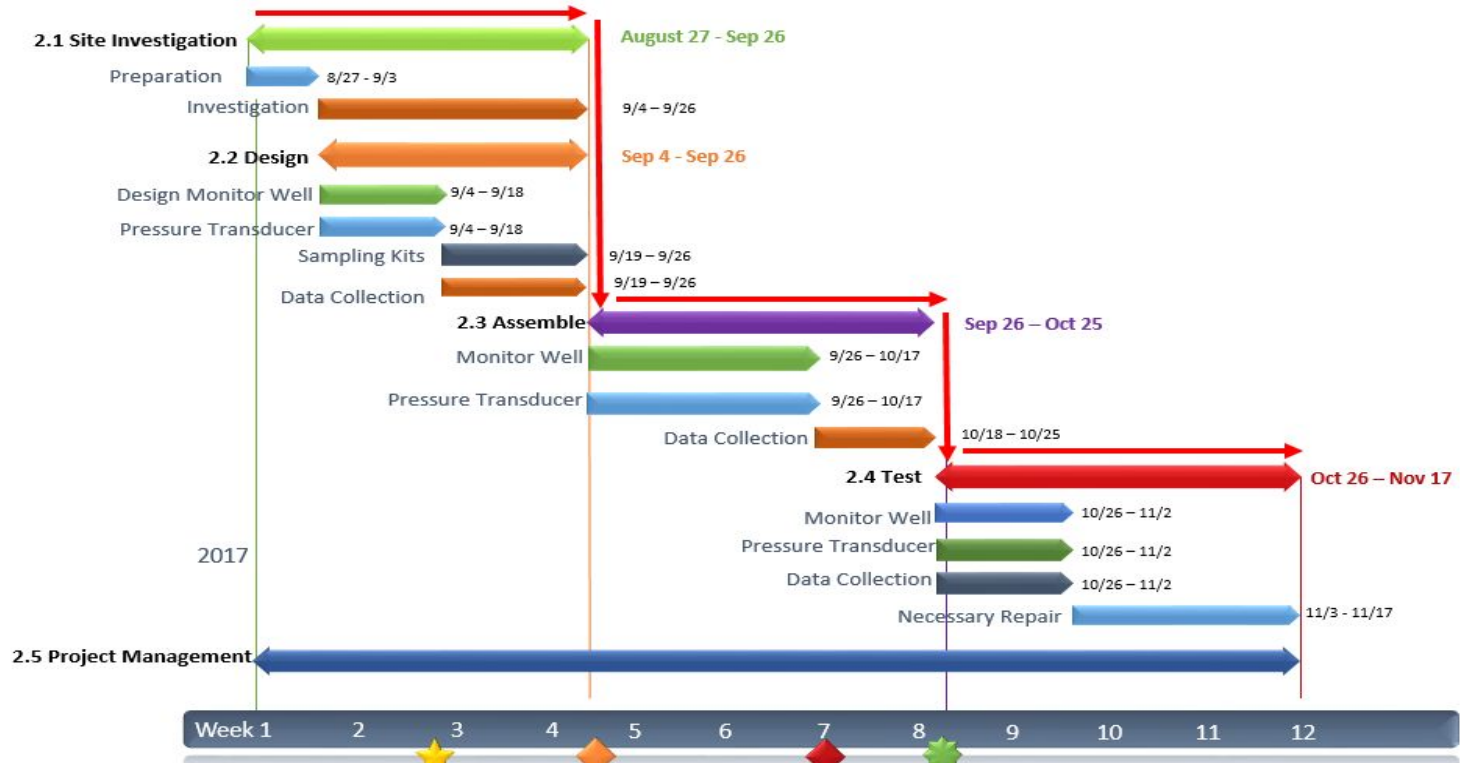

Tue Sep 19  
 Monitor Well Scheme  
 Pressure Transducer Scheme  
 Wed Sep 27  
 Rough Map  
 Sampling Kits Scheme  
 Data Collection Scheme  
 Wed Oct 18  
 Monitor Well  
 Pressure Transducer  
 Wed Oct 26  
 Data Collector

\* → Indicates critical path

# Budget

Consulting Services	Total Time (hrs)	Rate USD/hour	Estimated Budget(USD)	Engineering Services	Estimated Budget(USD)
Senior Engineer	190	70.00	13,300.00	Site investigation	50.00
Design Engineer	180	80.00	14,400.00	Monitoring Well	100.00
Project Manager	210	80.00	16,800.00	Sampling	100.00
EIT	150	60.00	9,000.00	Static water level detection	400.00
				Water Quantity detection	50.00
				Data Transmission	85.00
Total Labor Cost			53,500.00	Total Engineering Cost	785.00

# Acknowledgements

- Northern Arizona University SICCS
- The Arboretum at Flagstaff
- Dr. Dianne McDonnell PE (Technical Advisor)

# References

- [1] "Climate Change", thearb.org. [Online]. Available: <https://www.thearb.org/conservation/climate-change/>.
- [2] "Gardens | SEGA". Sega.nau.edu. N.p., 2017. Web. 26 Apr. 2017.
- [3] "For K-12 Students | Nano", *Nano.gov*, 2017. [Online]. Available: <https://www.nano.gov/education-training/k12>.
- [4] "Northern Arizona University - The World Looks Different from Here", *Northern Arizona University*, 2017. [Online]. Available: <http://nau.edu/>.
- [5] "The Arboretum at Flagstaff (AZ): Top Tips Before You Go - TripAdvisor", *Tripadvisor.com*, 2017. [Online]. Available: [https://www.tripadvisor.com/Attraction\\_Review-g60971-d126841-Reviews-The\\_Arboretum\\_at\\_Flagstaff-Flagstaff\\_Arizona.html](https://www.tripadvisor.com/Attraction_Review-g60971-d126841-Reviews-The_Arboretum_at_Flagstaff-Flagstaff_Arizona.html).
- [6] "Well Monitoring Directions", bemp.org. [Online]. Available: <http://bemp.org/wp-content/uploads/2016/01/well-installation-and-monitoring-directions.pdf>.
- [7] "Bailers", envisupply.com. [Online]. Available: <http://www.envisupply.com/equipment/bailers.htm>.
- [8] "9500 Photometer | ysi.com", *Ysi.com*, 2017. [Online]. Available: <https://www.ysi.com/9500>.
- [9] "DelAgua - DelAgua Kits", *Delagua.org*, 2017. [Online]. Available: <http://www.delagua.org/delagua-kits>.
- [10]"USE OF SUBMERSIBLE PRESSURE TRANSDUCERS IN WATER-RESOURCES INVESTIGATIONS", Pubs.usgs.gov, 2017. [Online]. Available: <https://pubs.usgs.gov/twri/twri8a3/>
- [11]"Measuring Water Level in a Well: Using a Beeper Tape", Utdallas.edu, 2017. [Online]. Available: [http://www.utdallas.edu/~brikowi/Teaching/Field\\_Methods/Measuring\\_Water\\_Level.html](http://www.utdallas.edu/~brikowi/Teaching/Field_Methods/Measuring_Water_Level.html). [Accessed: 26- Apr- 2017].

**Any Questions?**